



*Variable Speed Drive*

*For 3 Phase AC Motor*

## NEW ND1 Series

1 Phase 220VAC Size 0.5 to 2HP

3 Phase 220VAC Size 3 to 5.5HP

3 Phase 380VAC Size 1 to 5.5HP



Your best choice  
Easy to use  
Space saving  
Energy saving

Engineering by Novem



# Features

- Latest IGBT technology
- New Compact design
- Low-noise motor operation thanks to high pulse Frequencies (Carrier frequency) 0 to 15 kHz and sound tone level 0- level 3)
- Frequency setting potentiometer is standard equipment
- 5 Digital input is programmable (Terminal FWD, REV, X1, X2 and X3) 20 Function assignment of input terminal
- Jog operation run by terminal (Jog FWD, Jog REV)
- The digital input terminals connection signal sink logic/source logic and NPN/PNP Sensor
- Two analog input
  - (0 to 10Vdc = Voltage input 12)
  - (4 to 20mA, 0 to 20mA = Current input C1)
- One programmable analog output (0-10Vdc, 0-20 mA = FMA) for meter
- One programmable relay output (30A/30B/30C)
- Output frequency 0.01 to 400.0 Hz
- 16 speed control & 15-step preset speed (Multistep frequency selection bit 0 to bit 3)
- Automation function (Pattern mode selection, stage time, Stage direction, 7 stage)
- Internal PID Controller for simple process control (PID Controller Group function)
  - Automatic torque boost
  - Linear V/f characteristic
  - Quadratic V/f characteristic (variable torque load/Fan and Pump)
  - Multipoint characteristic (programmable V/f characteristic)
  - REV Phase Sequence Lock
  - Flying restart
  - Automatic restart following mains failure or fault
  - Programmable acceleration/deceleration 0 sec to 3600 sec and S-curve characteristics
  - The alarm history for the 5 latest alarms is recorded
  - 3 Jump frequency
  - Short-circuit protection
  - Stall prevention
  - Overload warning (Lamp RUN Flash)
  - Removable keypad

# Function code

Function code group	Function code	Function
<b>Gr-1</b>	F101-F118	<b>Motor Function</b>
<b>Gr-2</b>	F201-F260	<b>Terminal Function</b>
<b>Gr-3</b>	F301-F368	<b>Frequency Function</b>
<b>Gr-4</b>	F401-F423	<b>Protective Function</b>
<b>Gr-5</b>	F501-F522	<b>Special Function</b>
<b>Gr-6</b>	F601-F636	<b>PID Controller</b>
<b>Gr-7</b>	F701-F707	<b>Service Function</b>

# Keypad switches and functions

## LED monitor

When the motor is running or stopped :  
The monitor displays the speed monitor (such as output frequency, set frequency, output current, output voltage, DC-bus voltage, Motor speed, Lines speed).  
Alarm mode: The monitor shows the cause of Trip with a fault code.

## Up/Down keys

During operation : Used to increase or decrease the frequency or motor speed. This key is valid if the function code F301=0  
In data setting : Used to indicate the function code Number or to change data set value.

## Data key

Used to change the LED monitor and to store the function code and data.

## Unit display

The unit of the displayed at the LED monitor is indicated. Use the data key to switch the Displayed data.

## Program key

Programming mode :  
Used to set data.

## Potentiometer

Used to set the frequency and issue the PID process commands.

## Run key

While the motor is stopped :  
Used to start the operation. This key is invalid if the function code F201=1 (operation by external signals).

## Stop key

Used to stop the operation.  
During operation: This key is invalid if the function code F201=1 (operation by external signals).  
Alarm mode : Resets a trip prevention mode.



# Keypad mounting dimension

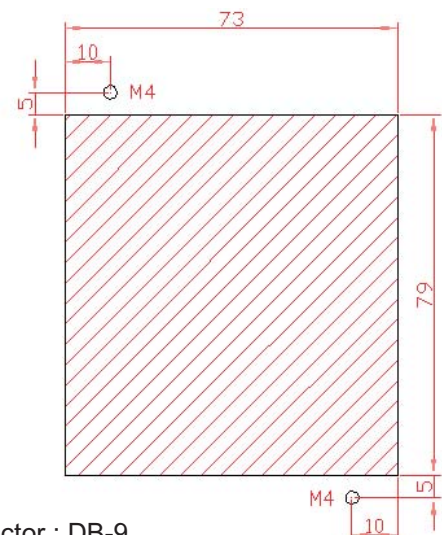
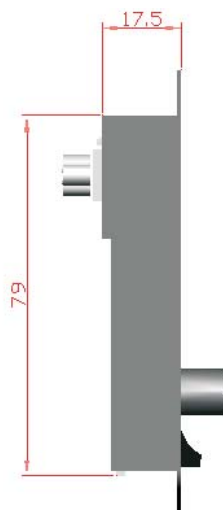

Connector : DB-9

# External Dimensions

Fig.1

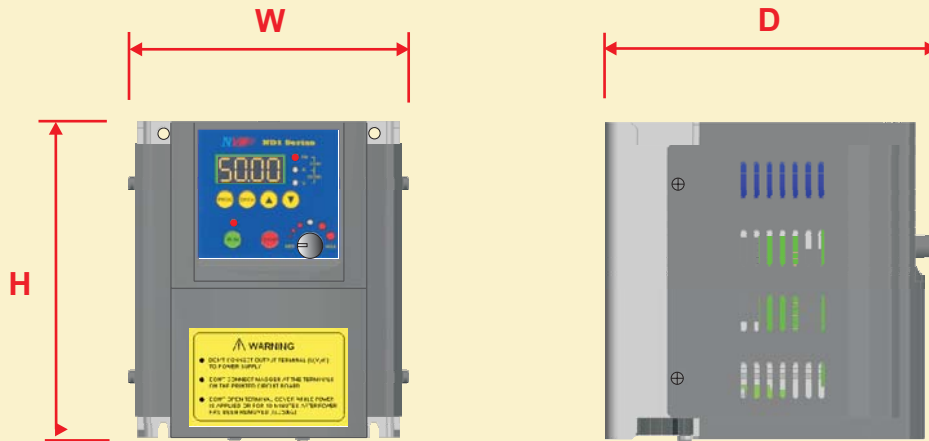
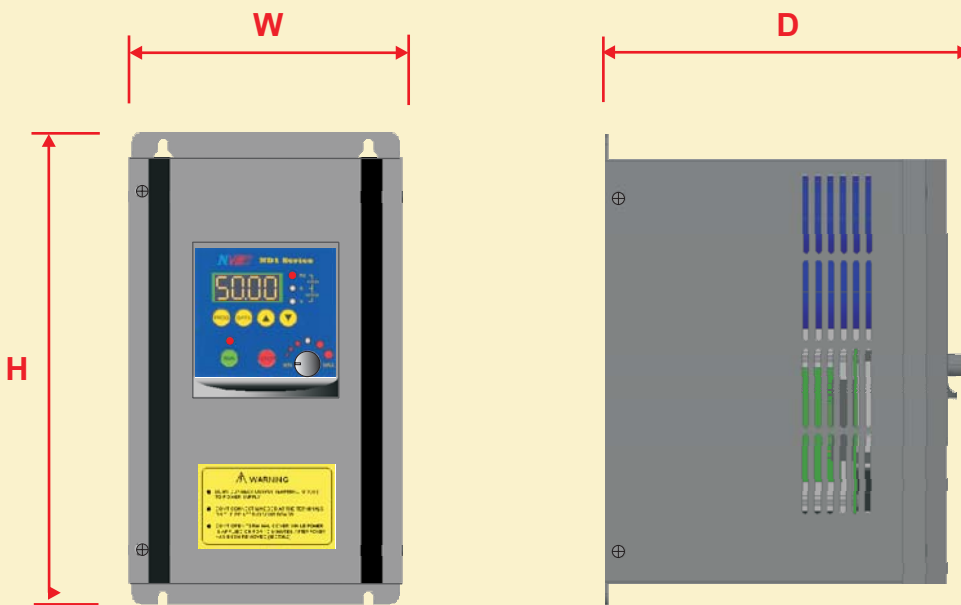

Fig.2



Power supply voltage	Model	HP	OUTPUT (A)	W x H x D ( mm. )	Braking Unit	Cooling Method	Fig.
Single-phase 220VAC	ND1-2-0A5	0.5	3.3	125 x 147 x 145	Not include	Self-cooling	1
	ND1-2-001	1	5.3				
	ND1-2-002	2	8.0				
Three-phase 380VAC	ND1-4-001	1	3.5	128 x 147 x 155	Built-in	Forced air-cooled	2
	ND1-4-002	2	4.8				
	ND1-4-003	3	6.2	131 x 225 x 175			
	ND1-4-5A5	5.5	11				
Three-Phase 220VAC	ND1-2-003	3	11	131 x 225 x 175	Built-in	Forced air-cooled	2
	ND1-2-5A5	5.5	17.5				

บริษัท โนวემ เอนจิเนียริ่ง จำกัด NOVEM ENGINEERING CO., LTD.  
 227/1 ซอยพื้งมี 11 ถนนสุขุมวิท แขวงบางจาก เขตพระโขนง กรุงเทพฯ 10260  
 Tel. 02-3319941-3, 02-7420716-23 Fax. 02-3319944  
 Website : [www.novemeng.com](http://www.novemeng.com) E-mail : [sales@novemeng.com](mailto:sales@novemeng.com)

# Wiring Diagram

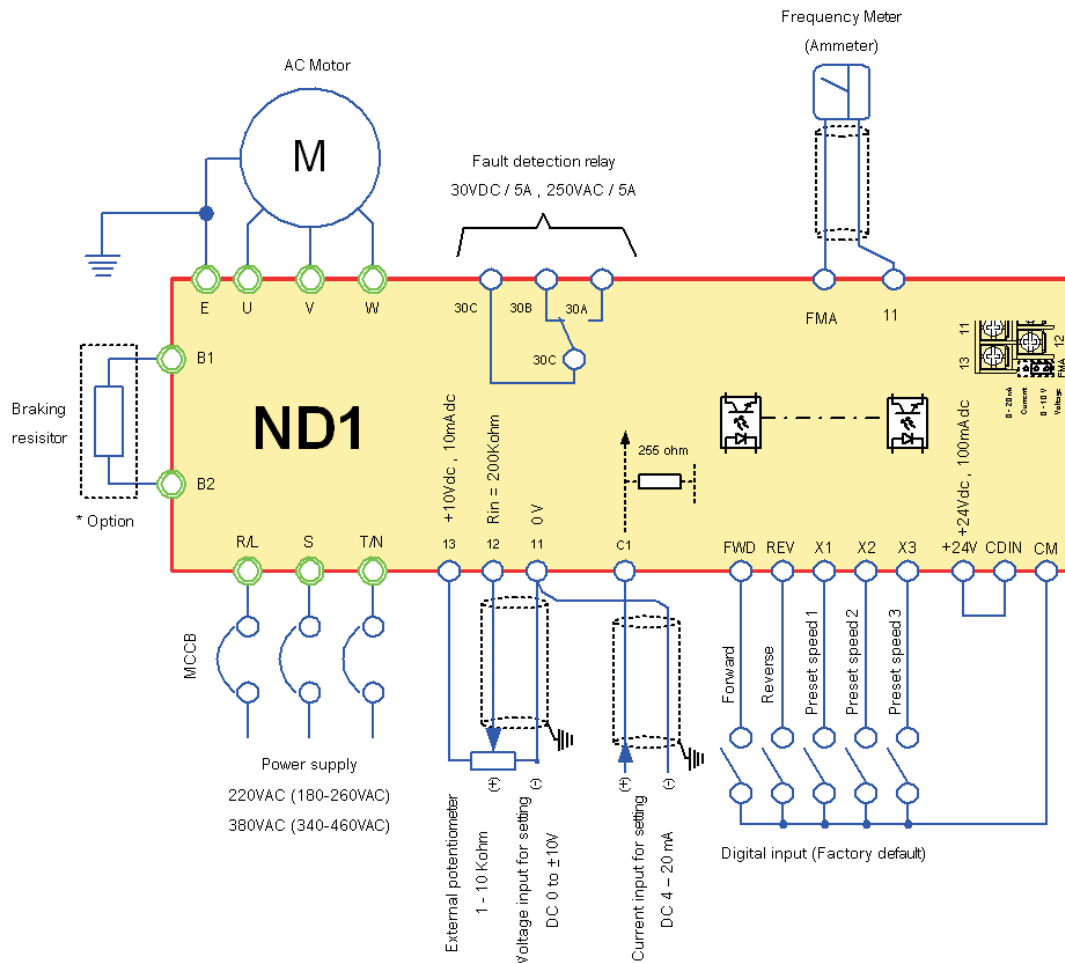

## ● Control circuit terminal (common to all the inverter models)

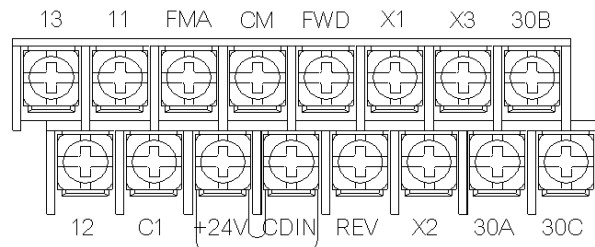

Terminal size : M3

# PID Control block diagram

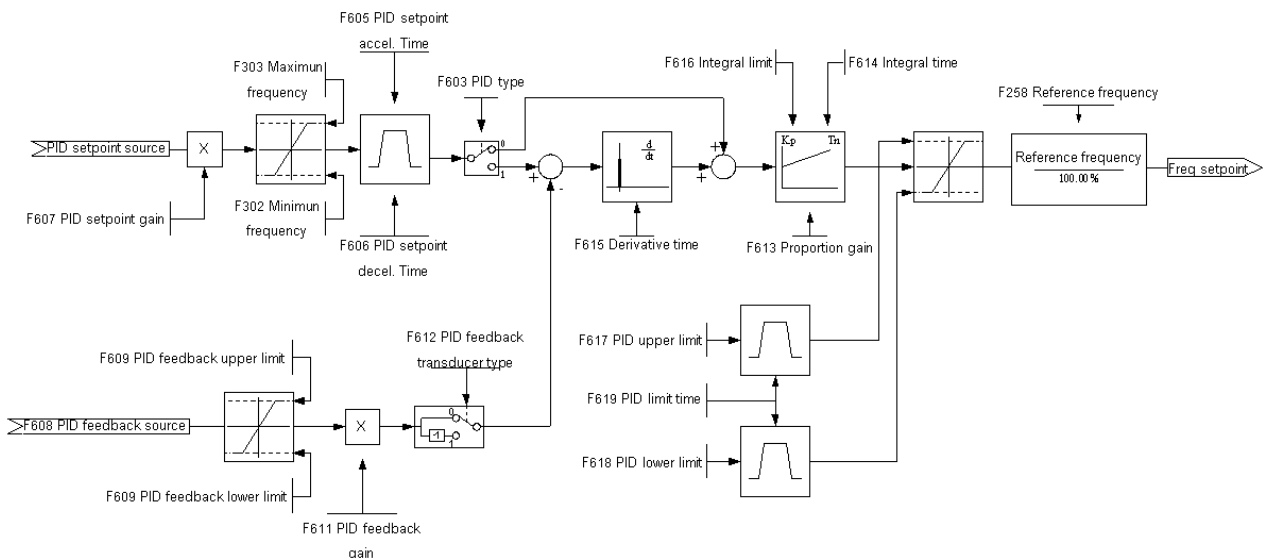

# Common specification

	Item	Specification
Principal control functions	Control system	Sinusoidal PWM control
	Rated output voltage	Adjustable within the range of 80 to 480V by correcting the supply ( not adjustable above the input voltage)
	Output frequency range	0.5 to 400.0 Hz default setting : 0.5 to 60 Hz , maximum frequency 10 to 400 Hz
	Minimum setting steps of frequency	0.01 Hz: operation panel setting ,0.1Hz: analog input ( when the max. Frequency is 100 Hz )
	Frequency accuracy	Digital setting : within 0.01% of the max. frequency Analog setting : within 1.0 % of the max ferquency
	Voltage/frequency characteristics	V/f constant ,variable torque , automatic torque boost .Base frequency ( 5-400Hz ) adjusting frequency at start ( 0 – 20Hz )
	Frequency setting signal	Potentiometer on the front panel ,external frequency potentiometer ( connectable to a potentiometer with a rated impedance of 1 – 10 k ),0 – 10Vdc (input impedance : 12 = 200kOhm ),4 – 20 mAdc ( Input impedance : 255 Ohm )
	Frequency jump	Three frequencies can be set . Setting of the jump frequency and the range.
	Upper and lower-limit frequencies	Upper-limit frequency: 0 to max frequency,lower-limit frequency: 0 to max frequency
	PWM carrier frequency	Adjustable within a range of 1 to 15kHz ( default : 10 kHz for 220V, 4kHz for 380V)
	PID control	Setting of proportional gain, intergral time ,differential time .
Operation specifications	Acceleration / deceleration time	Selectable from among acceleration /deceleration times can be independently set with 4 type and selected with digital input signal 2 point ( 0.0 to 3600 sec) S-pattern value adjustable.
	DC braking	Braking start-up frequency: 0 to 20.00 Hz, braking level : 0 to 30.0 % ,braking time : 0 to 600 seconds
	Input terminal function ( programmable )	Possible to select from among 20 functions , such as forward/reverse run signal input, jog forward /jog reverse run signal input, reset signal input .Logic selectable between sink and source by jumper position terminal CDIN,CM and +24V
	Output terminal function ( programmable)	Possible to select from 20 function, such as minimum/maximum frequency signal output, failure signal output,to assign to FL relay output.
	Forward /reverse run	The RUN and Stop key on the operation panel are used to start and stop operation respectively. The switching between forward run and reverse run can be done from two control unit : operation panel and terminal board.
	Jog run	Jog operation from the operation on the terminal board
	Preset speed operation	Main ferquency speed ,+15-speed operation possible by changing the combination of 4 contacts on the terminal board
	Auto-restart operation	In the event of a momentary power failure ,the inverter reads the rotation speed of the coasting motor and outputs a frequency appropriate to the rotational speed in order to restart the motor smoothly. This function can also be used when switching to commercial power.
	Override function	The sum of two analog signal input and multistep speed by digital input can be used as a frequency command value
	Failure detection signal	1c-contact output : ( 250Vac 5.0A)
Protective function	Protective function	Stall prevention, current limitation, over-current, output short circuit,over-voltage, under-voltage, overload protection by eletronic thermal function
	Reset function	Function of resetting by closing contact 1a or by turning off power or the operation panel (Stop key ) .
	Over load Capability	150% of rated current for 1 min.
Display function	Alarms	Overvoltage, overload, under-voltage ,output short circuit
	Monitoring function	Such as set frequency ,output frequency ,motor speed ,load shaft speed ,output voltage, output current ,causes of past trip 0 through 4
	Past trip monitoring function	Stores data on the past four trips:
	Output for frequency meter	Analog output ( full-scale DC 10Vdc or 20 mA )
	4-digit 7-segments LED	Frequency : inverter setting ferquency, output frequency Alarm: OC: Overcurrent , OU: Overvoltage,OH: Overheating of the heat sink,OL: Overload,SC: Output short circuit, HE: External fault ,LU: Under voltage,
	Indicator	Lamps indicating the inverter status by lighting ,such as RUN lamp , Hz lamp, Amp lamp, Voltage lamp,r/min lamp,m/min lamp, frequency setting pottentiometer lamp,
Environments	Use environments	Indoor, not exposed to direct sunlight not exposed to direct corrosive gas not exposed to direct explosive gas
	Ambient tempreature	-10 to 40 C
	Storage tempreature	-10 to 60 C